



Power Inverter
Líderes en transformaciones de energía



USER'S MANUAL

Wind Turbine 400w

1



Model	WIN 400W – POWER INVERTER
Rated power	400W
Maximum power	410W
Rated voltage	12V/24V
Start up wind speed	2.0m/s
Rated wind speed	11.5m/s
Survival wind speed	50m/s
Top net weight	9.5kg
Wheel diameter	1.55m
Blades number	3/5
Blades material	Nylon fiber
Generator	Three phase permanent magnet ac generator
Magnetic steel	NdFeB
Generator case	Die-casting aluminum
Control system	Electromagnet
Speed regulation	Automatically adjust windward
Working temperature	-40°C ~ 80°C
Gross weight	9.5kg
Dimension of carton	23*30*72cm

Distinguished Users:

We are very glad that you choose our company's products and feel sure that you will find the convenience that our products bring to you and the joy of promoting the policy of “low carbon and environmental protection”.

Please do not forget to read the “User Installation Manual” before installing of the products.

Catalogue

Part1. Safety Warning and the Attention -----	3
Part2. Product Description-----	6
Part3. Tower and Accessories Production-----	7
Part4. The Wind Turbine Installation Steps-----	9
Part5. The Connection between Transmission Line and the Controller-----	12
Part6. The Maintenance and Attention in Operation-----	13
Part7. Packing list-----	14
Part8. Quality Guarantee-----	15

Part1. Safety Warning and the Attention



Attention:

For correct installation and use of this equipment, please read carefully the safety warning and attention and strictly follow the instructions.

Basic requirements:

- Do not disassemble the equipment by yourself. Please contact the specified maintenance department when the equipment is out of order.
- Without authority, no company or individual are allowed to change the equipment structure, safety and performance design .
- please obey local laws and regulations when using this product

Assembly Requirements:

1. Before the assembly of the wind generator or in the process of maintenance, please be sure to read the users manual first..
2. Please don't install the wind turbines in rainy days or when the wind scale is at Level 3 or above.
3. After opening the package, it is advised to short circuit the three leads of the wind turbines (the exposed copper parts should be screwed together).
4. Before the installation of the wind turbine, lightning grounding must be prepared. You can arrange the facilities according to national standards, or you may arrange them according to the local environment and soil condition.
5. When assembling the Wind turbine, All the parts should be fastened with fasteners specified in table1.
5. When assembling the Wind turbine, All the parts should be fastened with fasteners specified in table2

Table 1



Product Details

The blade has built-in copper inlay, and the bolt tightening doesn't damage the nylon fiber so that it is not easily deformed or broken.



1. The patented generator has low torque and high efficiency at startup. 2. Using high temperature Teflon wire, not easy to burn out the wire in the generator overload fever.



The hub grooves and blades are designed with tight matching to make the matching between the blade and the hub more accurate.



Power Inverter
Líderes en transformaciones de energía



Double groove ball bearings using thicker, when the machine is running is not easy to shake.

Serial#	Fasteners	spec	quantity	tightening torque (N*M)	remarks	Executive standard
1	Flange bolts	M12*55	4		galvanized	
2	Flat washer	D12.2	8		galvanized	
3	Spring washer	D12.2	4		galvanized	
4	Lock nut	M12	4	≥58	one-time use	
5	Bolts for blades	M6*40	6/10			
6	Lock nut for blades	M6	6/10	≥13.6	one-time use	
7	Lock nut on shaft	M16	1	≥68	one-time use	

6. Before the connection between the wind turbine flange and the tower flange, please connect the three leads of the wind turbine to the three leads of the tower accordingly. When using the hinge method, every pair of wires should be no less than 30mm in length and be wrapped with Acetate cloth tape for three layers, then sheathed with spun glass paint tube. With this method, connect the three pairs of wires (attention: the joint of the wires can't bear the weight of the tower leads directly, so wires 100mm downward from the joint should be wrapped with adhesive tape and then stuffed into the steel pipe. After that, wind turbine flange and tower flange can be connected.

7. Before hoisting the wind turbines, the end (which should be connected with controller) of the tower lead should be cut away the insulating layer for 10mm or so. Then screw the three exposed leads (short circuit) together.

8. During the installation, it is prohibited to revolve the rotor blades roughly (the ends of wind turbine leads or the tower leads are short-circuited at this moment). Only after all the installation and the examination is finished and the security of the erection crew is guaranteed, it is allowed to dismantle short circuited leads and then connect with

controller and battery before running.

Attention:

Battery should be connected with controller before wind turbine connected with controller

If above stated instruction are not followed when assembling and installing the wind turbines, we are sorry that any problem or failure resulted are not to be covered by warranty.

Part2. Product Description

1.low start up speed; high wind energy utilization; beautiful appearance; low vibration

2.Human friendly design, easy installation, maintenance and repair.

3.precise injection molding blades together with the optimized design of aerodynamic contour and structure, the blades have such advantages: high utilization of wind energy which contributes to the annual energy output.

4.the generators, adopting patented permanent magnet rotor alternator, with a special kind of stator design, efficiently decrease resistance torque.Meanwhile, it makes the wind turbines match the generators quite well and increase its reliability

Part 3.Tower and Accessories Production

1.its flange base is suggested to be installed on a iron barrel-type tower whose OD is 48mm and thickness is 4.5mm.

2,Iron pipe length is suggested to choose based on local wind scales and geographical environment.

3, tower accessories, including (1)the upper tower. (2) The cable group. (3) Tightening line device. (4) Anchor. (5) Line hook. (6) tower base. (7) Anti-tarnish, anticorrosive, coating materials.

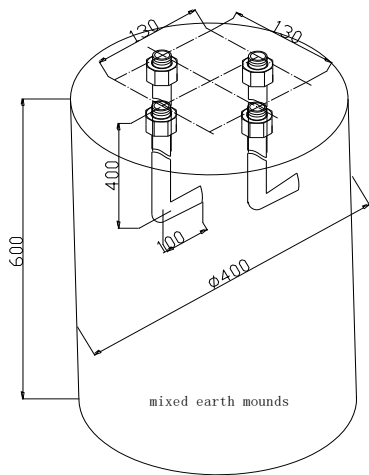

Figure1:manufacture of mixed earth mound

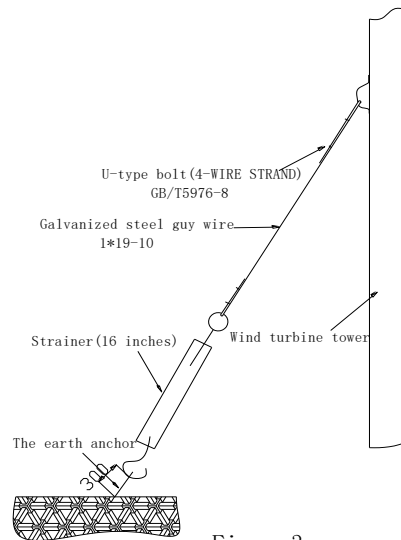

Figure3
The manufacture of guy cable

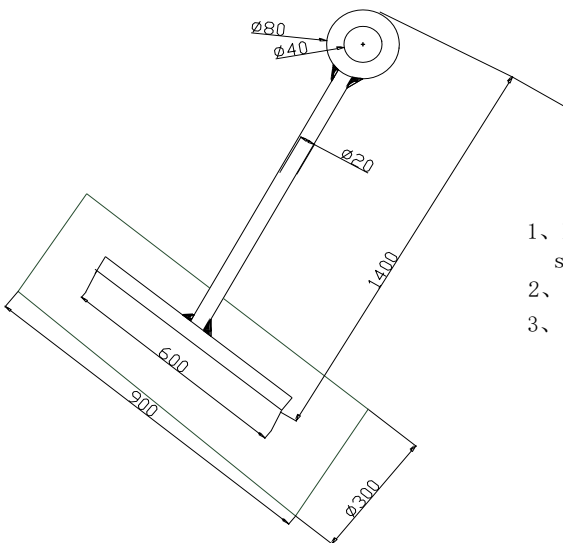

Figure2

The manufacture of earth anchor(3 sets)

Technical requirement

- 1、 L-type bolts for four galvanized wire strands; screws should be 60 higher from the mixed earth surface.
- 2、 C25 motar can be used for mixed earth.
- 3、 The metal parts should be under the threatment of anticorrosion and rust proofing.

Figure 1 the fabrication of anchor, lasso and guy cable

4. The making and size of the upper tower is shown in figure 2. Its requirement: solid welding; no leak at the weld zone; the earth lug must be welded 20cm away from the ground(clearly visible). It will be connected to the lightning grounding device.

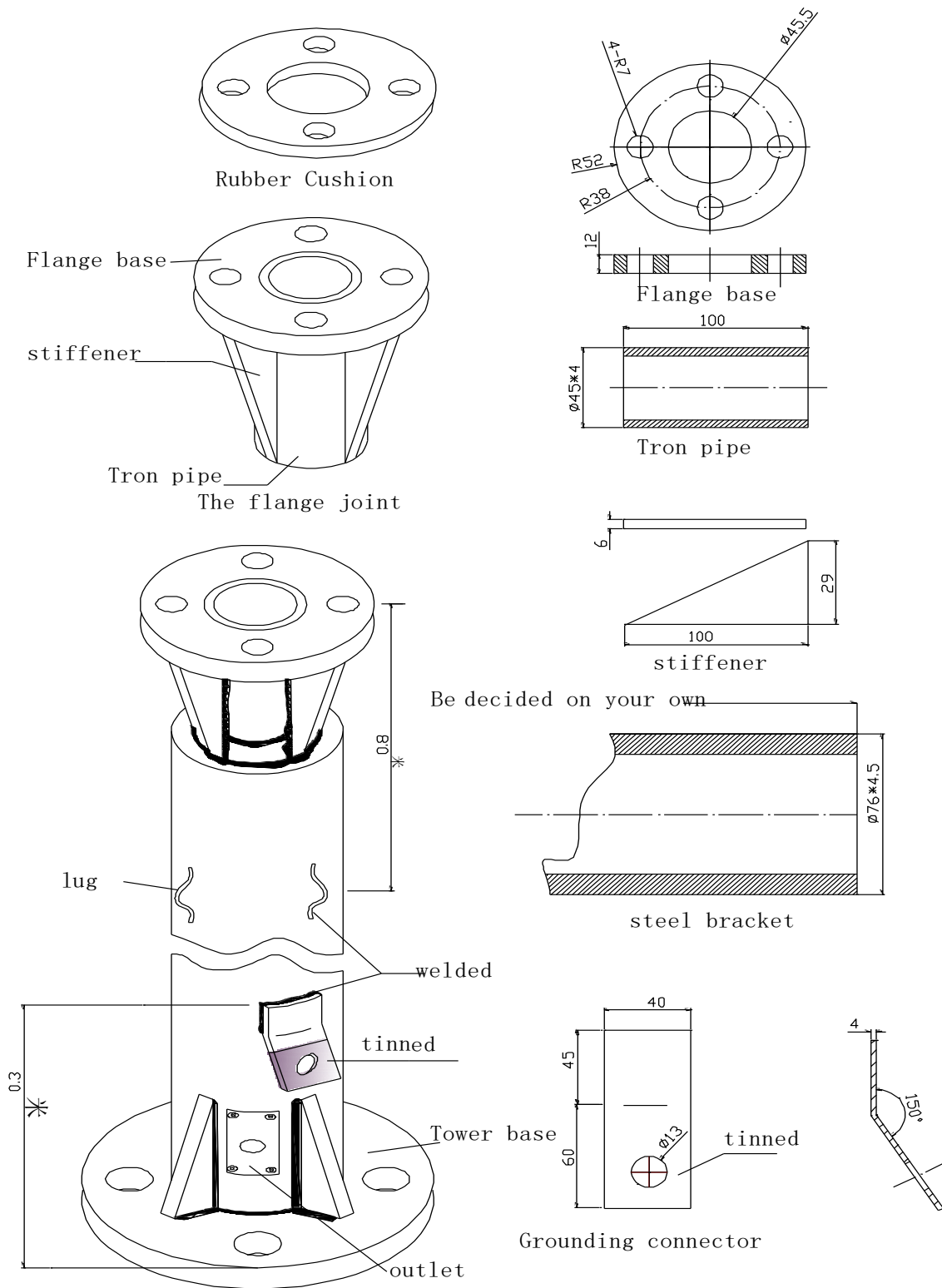

figure 2 wind turbine flange connection in the top of tower

5. Please refer to the national standard, or the European standard, or American standard or figure 1 in this manual

to arrange grounding device.

6. Tower and its accessories can be provided individually according to your requirements

Part 4. The Wind Turbine Installation Steps



It is prohibited to assemble and install wind turbines in rainy days.

1. The insulated current transmission wires: transmission lines are built in the iron pipe tower. The upper end is led out through the center bore of the wind turbine flange, while the bottom end are led out from the pipe opening which is 30cm away from the ground. The section from the opening to the point which is 60cm beneath ground should be protected by iron pipes whose O.D should be 17mm to 21mm. The underground paths of the transmission lines to the controller can be made arrayed and covered with iron pipe or a plastic pipe.

2. The installation sequence of the wind turbines can follow the steps as illustrated in figure 3.

2-1. Place the steel bracket on the ground; block up the flange joint to 1.3m.

2-2. Align the wind turbine flange to the tower flange. Cut away insulating layer of current transmission wire end (which are to be connected with controller) for 10mm , then short circuit the exposed copper wires(screwed together)

2-3. After the flange bolt (9) is mounted with the flat washer (10), plug it in the correspondent holes of the wind turbine flange with the bolt's head up, then through tower flange holes. Set the bolt into the flat washer, spring washer and then use a spanner to tighten the nut with the flange bolts. Similarly, plug other bolts, flat washer, spring washer and nuts in the corresponding holes. Screw tight all nuts, please refer to table 2 about the potency dimension needed to tighten them.

3. Align the 2 holes in the blade(6) with 2 holes in the groove of hub(5), align accurately, then put stainless steel bolt(13) from blade to groove through the holes, then screw lock nut(14)(Attention: lock nut is one time use, screw

tight, do not screw loose, otherwise it will be out of use), installation of other blades follow the same operation, please refer to table 2 on force dimension of installation

4. First put the bigger end of lock nut into hexagonal hole centered in the hub, then onto the threaded shaft of the generator, press nut with left hand while rotate wheel clockwise with right hand, push nut, then use the lengthening hex wrench to assist right handed rotation of wheel, finally lock the nut (Attention: nut can only push forward, withdrawal is prohibited.) please refer to table 2 on force dimension of installation

5. Clasp fairing(8) with wheel hub(5), align the three notches with blades, clasp the cone of fairing to get notches to the seam of wheel hub

6. The lifting of the wind turbines and tower should be proceeded with the presence of skilled slingers and the security should be guaranteed. The tower's stance should be executed on the basis of the relevant requirement of permanent construction.

7. After installation of tower and lightning protection is finished, use 500V meggar to measure insulating resistance between transmission lines and earth (earth wire can act as ground) in the case of not loosing the short circuited leads of transmission lines, measurement should not be less than $5M\Omega$, otherwise, insulating layer may be crushed, damaged or moisted, should be dealt with immediately.



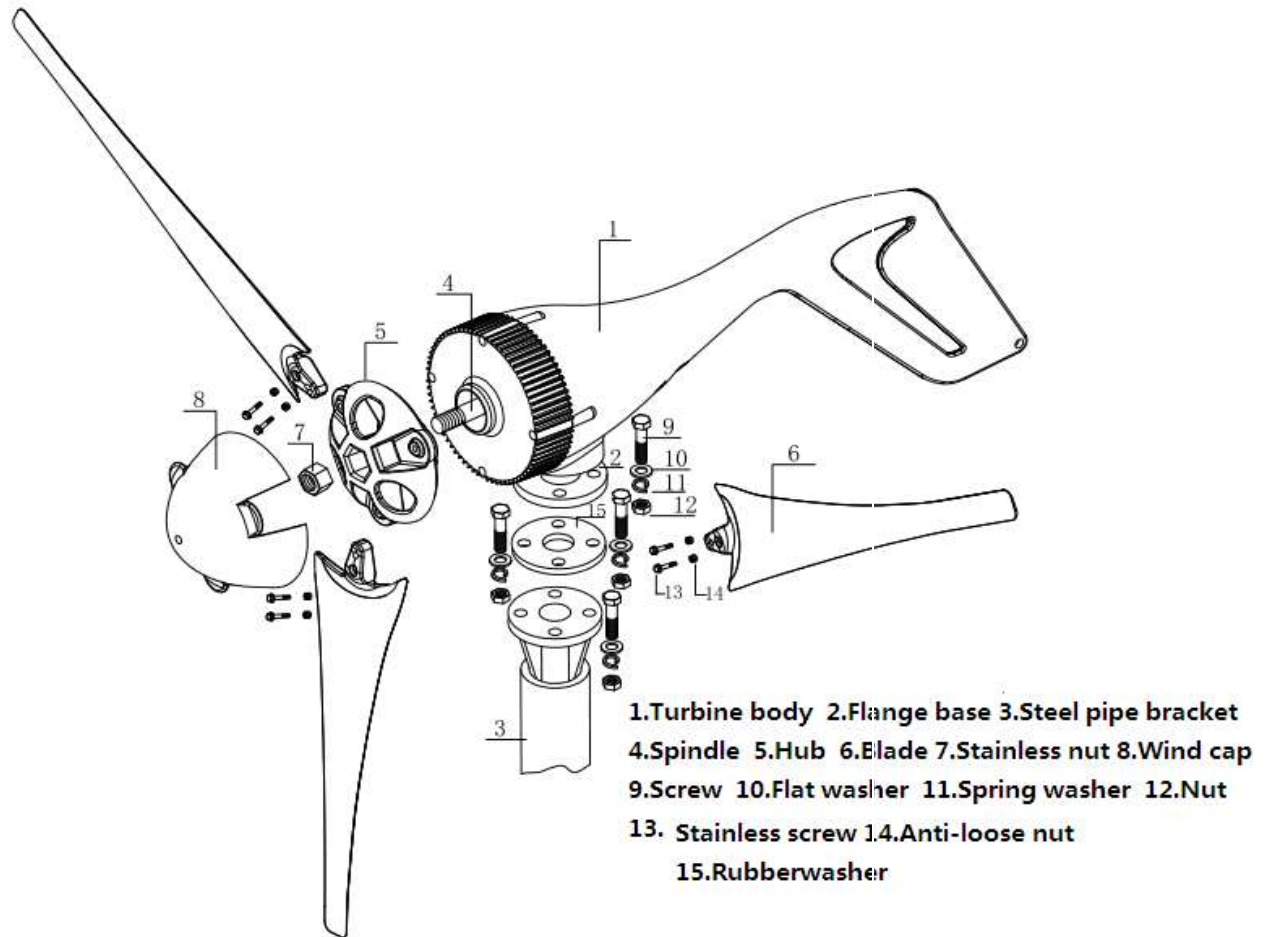

Figure 3 wind turbine decomposition

Part5. The Transmission Line Connection With current collectors



Avoid heavy rain days for the first commissioning. Priority should be given to the days with gentle breeze or strong wind(wind speed: 5~13m/s).

1. connect correctly the positive and negative pole of battery to the positive and negative pole of control inverter (control inverter specially for wind solar hybrid) (solar terminal is for spare use)

2. the load circuit connected to the socket on the back of control inverter by way of fuses,switches,plugs.

3. connect the three current transmission lines of wind turbine to the three terminals on the back of control inverter. please refer to control inverter manuals for detailed instruction.

4. Battery selection generally lead-acid battery preferred, 100w-.300W wind turbine 100AH -200AH battery optional, 300W-600W wind generator ,200 ~ 400AH battery optional, the upper and lower limits of charging voltage controlled by the inverter. The wind turbine using floating charge to battery , the floating current is affected by battery condition.

5. The controller should be placed in dry, well ventilated place, moisture and dust-proofed, inverter shell should be kept grounded and more than 1.5 meters away from the batteries to avoid acid gas pollution.

6. battery should be put in the dry,ventilated place, cool in summer, warm in winter,in such environment , battery can be better maintained

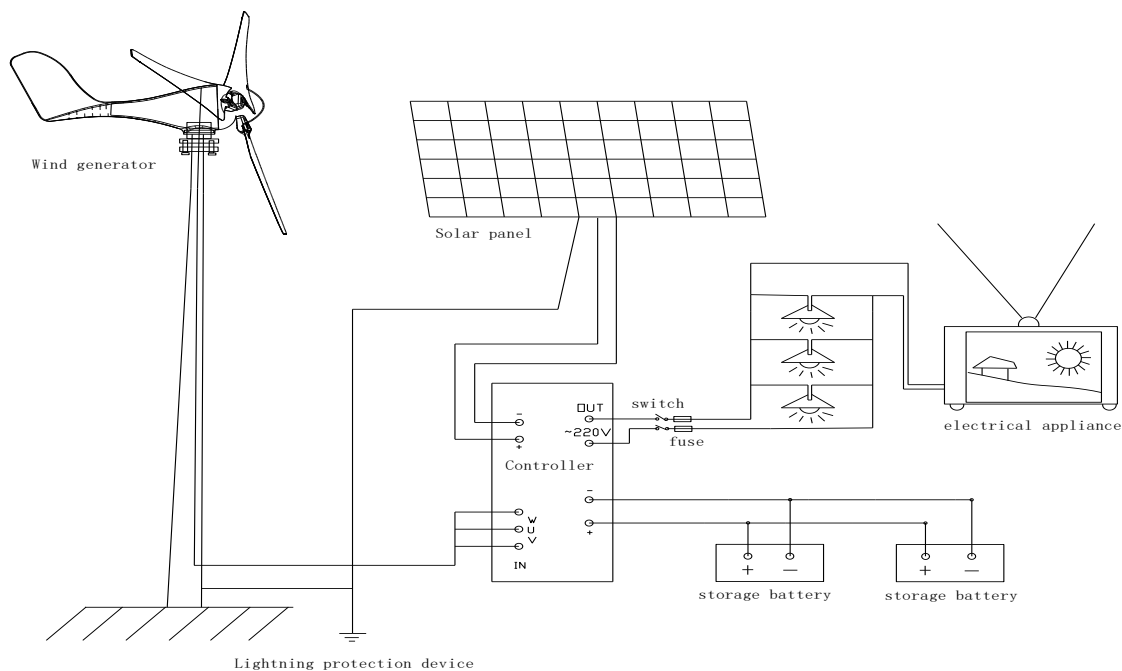

Connection diagram of wind turbine, solar panel & electrical appliance

Part6. Maintenance and Precautions

1.Wind generators often work at poor environment, thus please make sure to check regularly with your sight and hearing; check whether the tower is swaying or whether the cable is loose (using a telescope is also a good idea).

2.Timely inspection should be made after a heavy storm. If there is any problem, please put down the tower slowly for maintenance. With regard to the wind turbines for streetlights, there should be electrician climbing the pole to check if there is any problem when wind turbine have been short circuited and security protection measures

prepared.

3.The free maintenance batteries should be kept externally clear.

4. Do not disassemble the equipment by yourself. Please contact sales department when the equipment is out of order

Part 7.Paking List

Serial#	Item	Quantity	Remarks
1	Wind generator	1	
2	hub	1	
3	blades	3/5	optional
4	lock nut on shaft (M16)	1	
5	bolt for blades (M6*40)	6/10	optional
6	lock nut for blades (M6)	6/10	optional
7	flange bolt (M12*55)	4	
8	nut (M12)	4	
9	flat washer	8	
10	spring washer	4	
11	bolt for blades (M6*40)	1	optional
12	lock nut for blades (M6)	2	optional
13	L spanner	1	optional
14	hex wrench	1	optional
15	Controller / inverter	1	optional
16	tower	1	optional



1. The blade installed in the double holes (see the pc), stainless steel bolts insert the holes

2. Use L wrench screw up the every stainless steel bolt (3 groups, 6pcs)



3. First, mount the four flat gaskets on the four bolts, then insert the bolts into the holes e corresponding to the flange

4. The three wires connect the transmission cable, each length of the spliced wire not less than 30mm, fastened the connectors with tape, the length is about 100mm.



5. The flange seat installed in the tower, put flat gasket and elastic gasket, tighten the nylon nut.

6. The nut into the hexagonal hole, in the middle of the hub, placed on the spindle together, with the right hand fixed the wind wheel, left hand counter-clockwise rotating bolt, locknut.



7. Diversion cover is corresponding, to each blades, fasten tight the diversion cover

8. Before the three wires connecting to the controller, plz connect the batteries to the controller



Ps: The above information is for reference only, detailed installation information to see the INSTRUCTION

Par8. Quality Guarantee

1.The company guarantees customers that generator is of excellent quality,function is good, the body is complete,rigorously checked before delivery,

2,We provide 1 year's warranty for wind generator and 1 year for controller since the date of sale, damages occurred in the following situation:dismantle optionally by yourself or seriously violate operation (not according to instructions use) are not covered by warranty.

3, The documents are as a product warranty certificate, please keep it properly.

User information table:

Sales company:	Purchase company:
Purchase time:	Contact person:
SBBH:	Contact:
Model:	Zip code:

Maintenance records:

Date	Maintenance species	Summary	SMT rework